

3.50" DUAL PORTED PBL BYPASS SYSTEM

Operating Instructions

Receiving the Ball Locking PBL at the Rig Site

1. On receipt of the Ball Locking PBL, the tool should be checked for the following:
 - A shearing pressure for the ball seat and ports should be marked on the tool.
 - The tool box that comes with each tool should contain.
 - 4 x 1-1/4" torlon opening/activation balls
 - 8 x 1-1/16" steel closing/de-activation balls
 - 2 x 0.70" torlon locking balls
 - 1 x 1-1/4" weighted ball/dart

Make Up and Testing the PBL Sub at Surface (Optional)

1. Pick up the tool and make up the Circulating sub on top of the ball catcher sub. Ensure that the inner mandrel, of the circulating sub, is in the closed position by looking through the port on the side of the tool. Check that the ball catcher cage, of the ball catcher sub, with the bevelled end facing up and no-go cage on the bottom. Make-up torque is the same as the drill collar thread connection. **(Do not Over Torque).**
2. Pick up the Kelly and make up in the top of the tool.
3. Pick up string out of the slips and lower into the hole ensuring that the opening ports are below the rotary table with in drilling fluid.
4. Drop one (1) torlon activation ball 1-1/4" to activate the tool. It is recommended to fill up the drill string with fluid prior to dropping the activation ball.
5. Engage the pump very slowly and watch for the sleeve opening and the fluid diverting through the ports. It will not take a lot of pressure to overcome the spring tension when opening the sleeve (100 - 200 psi).
6. When fully satisfied that the tool is functioning properly, stop pumping, and pick up string and place in the slips. **The PBL Sub piston will close when the pumping is stopped.**
7. Break the Kelly and drop 2 x 1-1/16" STEEL de-activation Balls into the tool on top of the torlon ball.
8. Re-engage the Kelly and pick up out of the slips and lower the string so that the opening port is below the Rotary Table & within drilling fluids.
9. Engage the pump and record the pressure at which the torlon ball shears through the ball seat. **BUILD PRESSURE RAPIDLY.** This should be plus or minus 10% of the recorded pressure that was sent with the tool. (NB: De-activation Pressures are 'tool specific' and can vary from 1600 to 4500 psi).
10. With opening ball sheared and the port closed, keep pumping and lift the tool above the table to visually check the port is closed.
11. Stop the pumps, pick up string and place in the slips, and break the tool between the circulating sub and the ball catcher sub. Remove Kelly and back out the circulating sub from the string and retrieve the balls from the ball catcher. **Do not under any circumstances re-use the torlon opening balls once they have been used in the tool.**

Activation Procedure

1. **Prior to activating the tool, Record Pump Pressure _____ Pump Strokes _____.** This will be used as a reference to confirm de-activation of the tool.
2. Calculate the fluid displacement **volume and time** in the drillstring to estimate when the activation ball will reach the Bypass Tool. Break drillstring at floor and drop one (1) 1-1/4" torlon activation ball. It is recommended to fill the drill string with fluid prior to dropping the activation ball.
3. It is recommended to maintain normal drilling pump rates, keeping the pressure 1000 psi below the ball shearing pressure as indicated on the Tool Order. Displace 70% of the volume inside the drillstring, and then reduce the pump rate to 25% (Max. 400 GPM) until the ball lands on the seat. The torlon ball will often seat sooner than the calculated pump strokes. The torlon activation ball has an equivalent density of 11.2 PPG drilling fluid. **NOTE: Care should be taken when pumping the torlon ball down. Pumping the activation ball on seat at high fluid rates or pressures may cause the activation ball to blow through the seat.** In the event the ball does get blown through the seat, as indicated by pump pressure/strokes the same as step one, drop 2 steel 1-1/16" de-activation balls to ensure the torlon activation ball has gone through the seat. **This step must be done prior to dropping another torlon ball.** Return to the normal tool activation process to open the tool.
4. When the activation ball lands on-seat, the inner mandrel will shift to its open position against the spring. **NOTE: IT TAKES 100-200 PSI TO ACTIVATE /OPEN THE TOOL.** Fluid will now be diverted through the side ports. As long as pumping is continuous, fluid will be diverted through the ports. If pumping is halted, the sliding sleeve will shift to the closed position. When pumping resumes, the sleeve will shift open again allowing fluid diversion through the ports of the PBL Tool. It is recommended a constant, high pump rate be maintained while the tool is in the open position. **If low flow rates, low differential pressures between drill pipe and annulus, bullheading, squeezing or similar low flow operations are required, it is recommended to deactivate the PBL Tool before commencing such operations.**
 - Surface indication of the tool being in the open position is a pressure drop. **Compare pump pressure/strokes to rates and pressures recorded in step one.** Once the tool is open, pump rates can be increased to the desired rate above the ball deactivation shearing pressure. High pump rates/PSI will not push the ball through the seat and deactivate the tool. The deactivation pressure, marked on the tool, only applies after the steel balls have been dropped to deactivate the tool.
 - Rotating and reciprocating the drillstring is good practice while activating the PBL MultiactivatedBypassCirculatingSub.

De-Activation Procedure

1. Break the drillstring at rig floor and drop 2 steel 1-1/16" de-activation balls.
2. After dropping the steel de-activation balls, pump at 50% of the normal flow rates and watch for a pressure increase. When the steel balls reach the Bypass Tool, they will cut off flow through the ports creating an immediate pressure increase. Bring the pressure up as quickly as possible. A pressure decrease is an indication the torlon activation ball has blown through the seat and into the ball catcher. The steel balls will follow into the ball catcher. **The torlon ball will blow through the seat at +/- 10% of stated shear pressure depending upon down hole conditions.**
3. After the torlon ball shears through the seat, the sleeve will move to the closed position. Circulation will now be through the BHA.
4. When pumping is resumed, check that the pressure and strokes are the same as they were prior to activating the PBL Tool (See data recorded in step one, above).

NOTE: After tripping out of the hole, the balls must be removed from the ball catcher sub before RIH again. **The used torlon activation balls should be immediately discarded and NEVER RE-RUN. If the PBL sub is to be rerun after being activated, it is strongly recommended to deactivate the tool prior to tripping out of the hole to minimize the wear within the tool caused by tripping with the tool activated.**

Emergency Weighted Darts with Torlon Balls or Hollow Darts

A Weighted Dart inserted in a 1-1/4" torlon ball or a 1-1/4" Hollow Dart is supplied as part of the package of operating balls. **These Darts are to be utilized only in cases where it is not possible to pump down the Torlon Ball.** These ball/darts weighted 6-7 times greater than the standard torlon ball to facilitate quicker activation of the PBL sub when limited or no circulation is possible. **These ball/darts MUST be dropped in direction indicated below down the drillstring when activating the tool.** It is not recommended to utilize the ball/dart in well bores with angles greater than 55°.

Weighted Ball/Dart

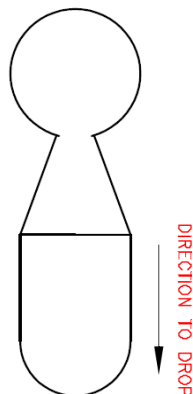

Hollow Dart

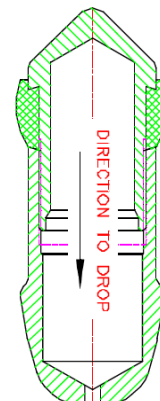

Should there be any questions regarding the operational procedures of the PBL tool please contact a DSI representative or visit our website www.dsi-pbl.com.

PBL OPERATIONAL SEQUENCE

PBL ACTIVATION



Drilling Mode
FLOW to BIT



Activation Ball
Seated

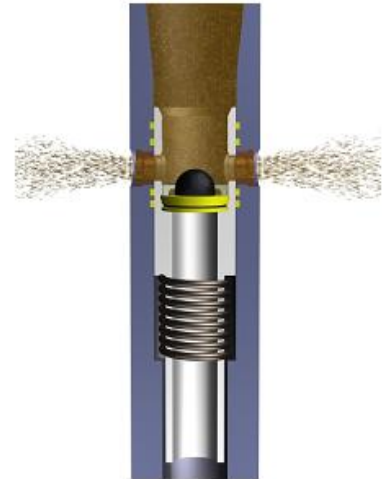

Open Position
FLOW THRU PORT

PBL DEACTIVATION



De-Activation
Balls Dropped
PRESSURE UP



Balls Sheared Thru
Seat Tool Reset



Drilling Mode
FLOW to BIT